

E. & U. S. DE MOULIN.  
INITIATING DEVICE.

(Application filed Feb. 20, 1900.)

(No Model.)

2 Sheets—Sheet 1.



Fig. 1.

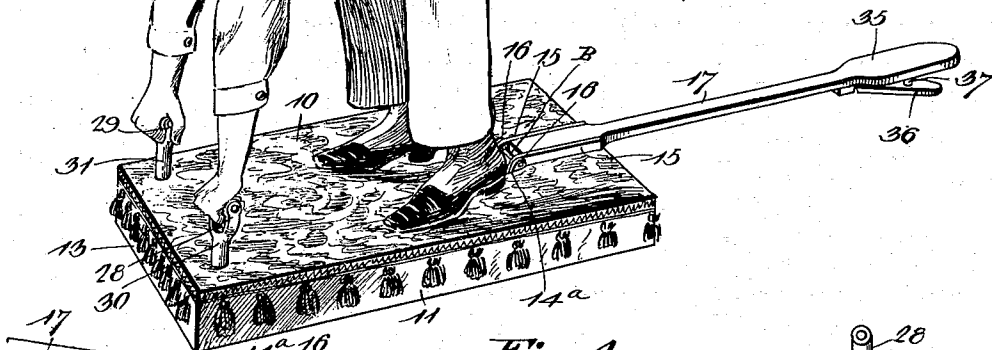

Fig. 4.

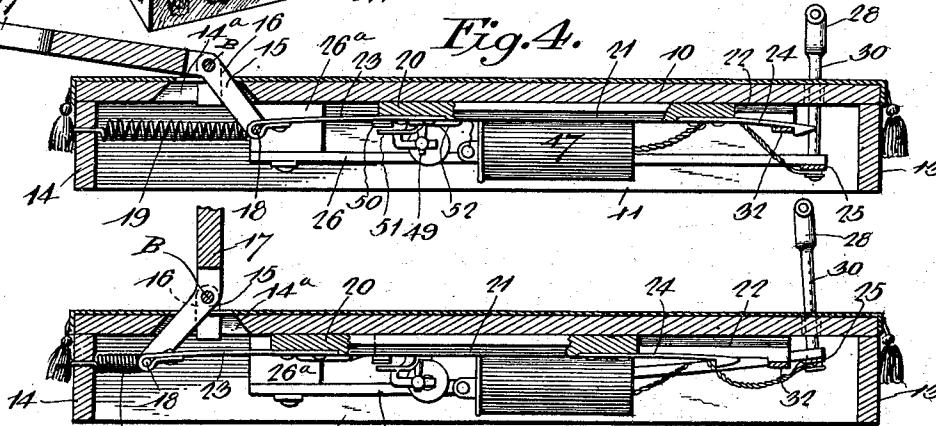

Fig. 5.

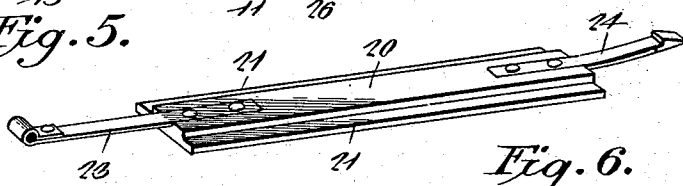

Fig. 6.

Witnesses  
*J. Kaufleberwill.*  
*Geot. H. Chamberlin.*

*Edmund De Moulin* & *Inventors.*  
 By their Attorneys, *Ulysses S. De Moulin,*

*C. Snow & Co.*

E. & U. S. DE MOULIN.

INITIATING DEVICE.

(Application filed Feb. 20, 1900.)

(No Model.)

2 Sheets—Sheet 2.

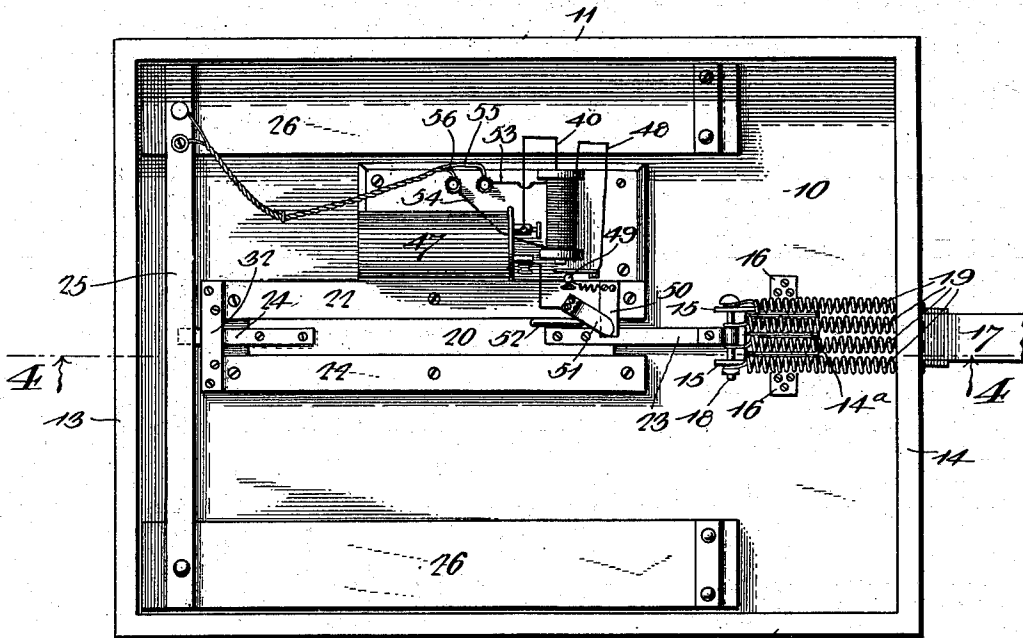

Fig. 2.

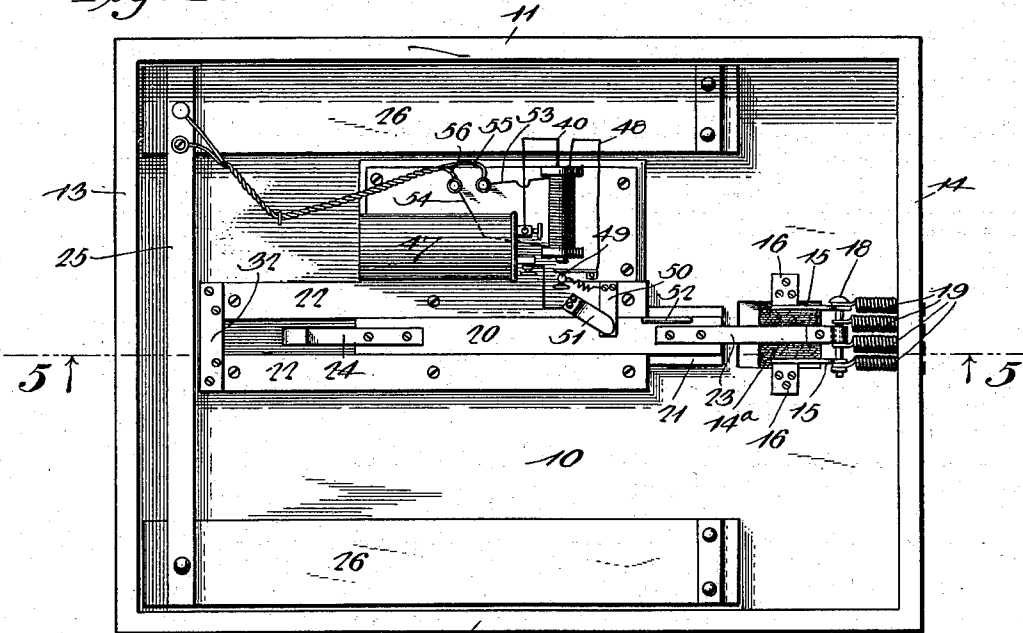

Fig. 3.

Witnesses  
*J. Frank Culverwell,*  
*E. H. Chandler*

*Edmund DeMoulin* Inventors.  
 By their Attorneys, *and Ulysse S. DeMoulin,*

*C. Snow & Co.*

# UNITED STATES PATENT OFFICE.

EDMUND DE MOULIN AND ULYSSES S. DE MOULIN, OF GREENVILLE,  
ILLINOIS.

## INITIATING DEVICE.

SPECIFICATION forming part of Letters Patent No. 654,611, dated July 31, 1900.

Application filed February 20, 1900. Serial No. 5,940. (No model.)

*To all whom it may concern:*

Be it known that we, EDMUND DE MOULIN and ULYSSES S. DE MOULIN, citizens of the United States, residing at Greenville, in the county of Bond and State of Illinois, have invented a new and useful Initiating Device, of which the following is a specification.

This invention relates to devices employed in initiating applicants for membership in secret organizations, &c.; and it has for its object to provide a device of this class which is in the nature of a spanking-machine, the construction being such that the applicant will be struck with a paddle and at the same time will be given an electric shock, the mechanism being thrown into operation by the applicant himself.

In the drawings forming a portion of this specification, and in which like numerals of reference designate corresponding parts in the several views, Figure 1 is a perspective view showing the initiating device and the position of the applicant in the act of operating it. Fig. 2 is a bottom plan view showing the mechanism set and ready for operation. Fig. 3 is a view similar to Fig. 2 and showing the parts after the mechanism is sprung. Fig. 4 is a longitudinal section showing the parts in their set positions, the section being taken on line 4 4 of Fig. 2 and showing parts in elevation. Fig. 5 is a section on line 5 5 of Fig. 3 and showing the mechanism sprung. Fig. 6 is a detail perspective view of the latch.

The mechanism of the present invention is inclosed in a platform comprising a top 10, sides 11 and 12, and ends 13 and 14. In the top 10 is formed an opening 14<sup>a</sup>, and through this opening are passed the ends of angular plates 15, which are pivoted by means of a pivot B to ears 16, carried by the top 10, and which plates are fastened to the sides of the base of a paddle 17. The inner ends of the plates 15 are connected by a cross-bar 18, with which are also connected a plurality of helical springs 19, having their opposite ends passed through the end 14 of the platform and attached thereto. The tendency of these springs 19 is to hold the paddle vertical and

at substantially a right angle to the position shown in Fig. 1. This paddle is adapted to strike an applicant standing upon the platform when released, after being drawn downwardly to place the springs 19 under tension, and in order to hold the paddle in its retracted position a latch mechanism is employed.

The latch mechanism comprises a follower 20, the side edges of which are reduced in thickness, as shown at 21, and are engaged with guideways 22, secured to the under face of the top 10. To one end of this follower 20 is secured a metallic strap 23, having its free end looped around the pin 18, while at the opposite end of the follower 20 there is secured a latch-tongue 24, of spring metal. A releaser for the latch-tongue 24 is formed by a metallic bar 25, the ends of which are secured to the under sides of the free ends of two spring-boards 26, the opposite ends of which are secured to the under side of the top 10 and mounted upon blocks 26<sup>a</sup>, adjacent the sides 11 and 12 of the platform, so that the free ends of the boards may be moved in the direction of the top 10. Handles 28 and 29 are mounted upon the upper ends of rods 30 and 31, which latter are passed through perforations in the top 10 and are secured at their lower ends to the bar 25, these rods 30 and 31 being adapted to slide freely through the top 10 to correspondingly move the bar 25. A keeper 32 for the spring-tongue 24 is secured to the ends of the guide-pieces 22 and in such position as to be engaged by the spring-tongue when the follower is moved in one direction. The proportions of the parts are such that when the paddle 17 is depressed to assume the position shown in Fig. 1 the follower 20 will be moved, through the medium of the plates 15 and strap 23, to engage the tongue 24 with the keeper 32. This keeper 32 is so positioned that when the tongue is engaged therewith the extremity of the tongue will project beyond the keeper and into the path of upward movement of the bar 25. Thus when the handles 28 and 29 are grasped and are drawn upwardly the bar 25, which forms the releaser, will engage the outer end of the spring-tongue and will move it upwardly and

away from the keeper 32, when the springs 19 will draw the latch-tongue from the keeper and will at the same time throw the outer end of the paddle upwardly. It will be seen upon reference to Fig. 1 of the drawings that the handles are so placed that in order to grasp them the applicant must stoop and will thus assume a position to be struck with the paddle. As shown in the several figures of the drawings, the outer end of the latch-tongue is beveled on its lower side, so as to ride freely over the keeper and move in one direction to snap the tongue into engagement with the keeper.

The head of the paddle consists of a rigid portion 35, which is formed integral with the stem and base, and comprises also a leaf 36, which is hinged to the head, at the under side of the latter, and has a projection 37 to receive a gun-cap. The momentum which the leaf 26 attains when the paddle is sprung is such as to throw the leaf against the head of the paddle with sufficient force to explode the cap.

In connection with the paddling mechanism above described an induction-coil is connected with the handles 28 and 29 and is adapted for operation during the upward movement of the paddle. This induction-coil comprises a primary winding one terminal 40 of which is connected with a pole of a battery 47, while its opposite terminal 48 is connected with one element of a make-and-break, the fixed contact 49 of which is connected with the opposite pole of the battery 47 or is adapted to be connected with the opposite pole of the battery 47 by engagement of two contact-plates 50 and 51, both of which are mounted upon the adjacent guide 22. The plate 51 lies below the plate 50, and both of these plates project outwardly and lie below the follower 20. This follower has a rib 52, fixed upon its lower face and of such length and height that it will engage the plate 50 and press it downwardly and into contact with the plate 51 during a proper portion of the time of upward movement of the paddle, the ends of the rib being beveled, as shown, to permit the rib to wedge above the contact-plate 50. The terminals 53 and 54 of the secondary winding of the induction-coil are connected with the handles 28 and 29 through the rods 30 and 31, one of the terminals of the secondary winding being connected through the medium of a wire 55 with the rod 30 through the bar 25, while the other terminal of the secondary is connected by means of the wire 56 directly with the rod 31. With this arrangement of induction-coil and battery, with their accompanying mechanism, it will be seen that when the rib 51 presses the spring 50 into engagement with the spring 52 the primary circuit will be closed and a shock from the secondary circuit will be transmitted through the handles. It will of course be understood, however, that, if preferred, the

plates 50 and 52 may be included in the secondary circuit, and the primary circuit may be kept closed, except for the make-and-break, during the operation of the device. 70

In using this initiating device the applicant for admission is first blindfolded and then placed in proper position upon the platform and is directed to grasp the handles and pull to test his strength, it being understood that the paddle has previously been drawn down and into operative position. When the handles are drawn upwardly, the bar 25 engages the latch-tongue and moves it from its keeper to release the follower, when the helical springs 19 act to draw the plates 15 rearwardly and throw the paddle upwardly to spank the applicant. At the same time the gun-cap is exploded and the electric shock passes through the arms of the applicant, making the sensation rather unique. 75 80 85

It will further be understood that changes may be made in the specific arrangement shown and that modifications may be made and also that any suitable materials and proportions may be employed without departing from the spirit of the invention. 90

What is claimed is—

1. In a device of the class described, the combination with a movable paddle and means for moving it, of means for holding the paddle against movement, means for releasing the holding means, an electric circuit including the releasing means, and means controlled by the paddle for energizing said circuit. 95 100
2. A device of the class described comprising a pivoted paddle, springs connected with the paddle, means for holding the springs under tension, means comprising handles for releasing the springs to operate the paddle, an electric circuit including the handles, and means controlled by the paddle for energizing said circuit. 105
3. A device of the class described comprising a pivoted paddle, springs connected with the paddle, a follower connected with the paddle, a keeper, a latch-tongue upon the follower and adapted to engage the keeper and hold the paddle with the springs under tension, a releasing device, and handles connected with the releasing device. 110 115
4. A device of the class described comprising a pivoted paddle, helical springs connected with the paddle, a follower connected with the paddle, a keeper, a latch-tongue mounted upon the follower and adapted to engage the keeper and hold the tongue with the springs under tension, a releasing-bar for engagement with the tongue to move it from the keeper, handles connected with the releasing-bar, a source of electricity, and connections between said source and the handles. 120 125
5. A device of the class described comprising a movable paddle, springs connected with the paddle for movement in one direction, a follower connected with the paddle, a latch-

tongue carried by the follower, a keeper for  
engagement by the latch-tongue, means for  
moving the tongue from the keeper, handles  
connected with said moving means, and an  
5 induction-coil having a secondary winding  
connected with the handles.

In testimony that we claim the foregoing as

our own we have hereto affixed our signatures  
in the presence of two witnesses.

EDMUND DE MOULIN.

ULYSSES S. DE MOULIN.

Witnesses:

HENRY C. DIEHL;

JESSIE B. BARR.